

INSTALLATION MANUAL

13493

Level of Difficulty

Easy

Installation difficulty levels are based on time and effort involved and may vary depending on the installer level of expertise, condition of the vehicle and proper tools and equipment.

Weight Carrying Capacity

Gross trailer weight (GTW) 3,500 lbs.

Tongue weight (TW) 350 lbs.

Weight Distribution Capacity

Weight distribution (WD) 4,000 lbs.

WD tongue weight (WDTW) 400 lbs.

Parts List

Item	Qty	Description
1	4	Hex bolt, 1/2"-13 x 4-1/2"
2	4	Flat washer, 1/2"
3	4	Serrated-flange nut, 1/2"

Tools Required

Ratchet	Wrench, 3/4"
Socket, 3/4"	Torque wrench

* For a tools reference guide visit curtmfg.com/trailer-hitch-installation

⚠ WARNING

Never exceed the vehicle manufacturer's recommended towing capacity.

Product Photo



NOTICE

Visit www.curtmfg.com for a full-color copy of this instruction manual, as well as helpful videos, guides and much more!

Before you begin installation, read all instructions thoroughly.

Proper tools will improve the quality of installation and reduce the time required.

Periodic inspection of the trailer hitch should be performed to ensure all mounting hardware remains tight and structural components are secure.

To help prevent damage to the product or vehicle, refer to the specified torque specifications when securing hardware during the installation process.

SAFETY INSTRUCTIONS

Safety glasses should be worn at all times while installing this product.

Product Registration and Warranty

CURT stands behind our products with industry-leading warranties. To get copies of the product warranties, register your purchase or provide feedback, visit: warranty.curtgroup.com/surveys

ASSEMBLY

Parts List

Item	Qty	Description
1	4	Hex bolt, 1/2"-13 x 4-1/2"
2	4	Flat washer, 1/2"
3	4	Serrated-flange nut, 1/2"

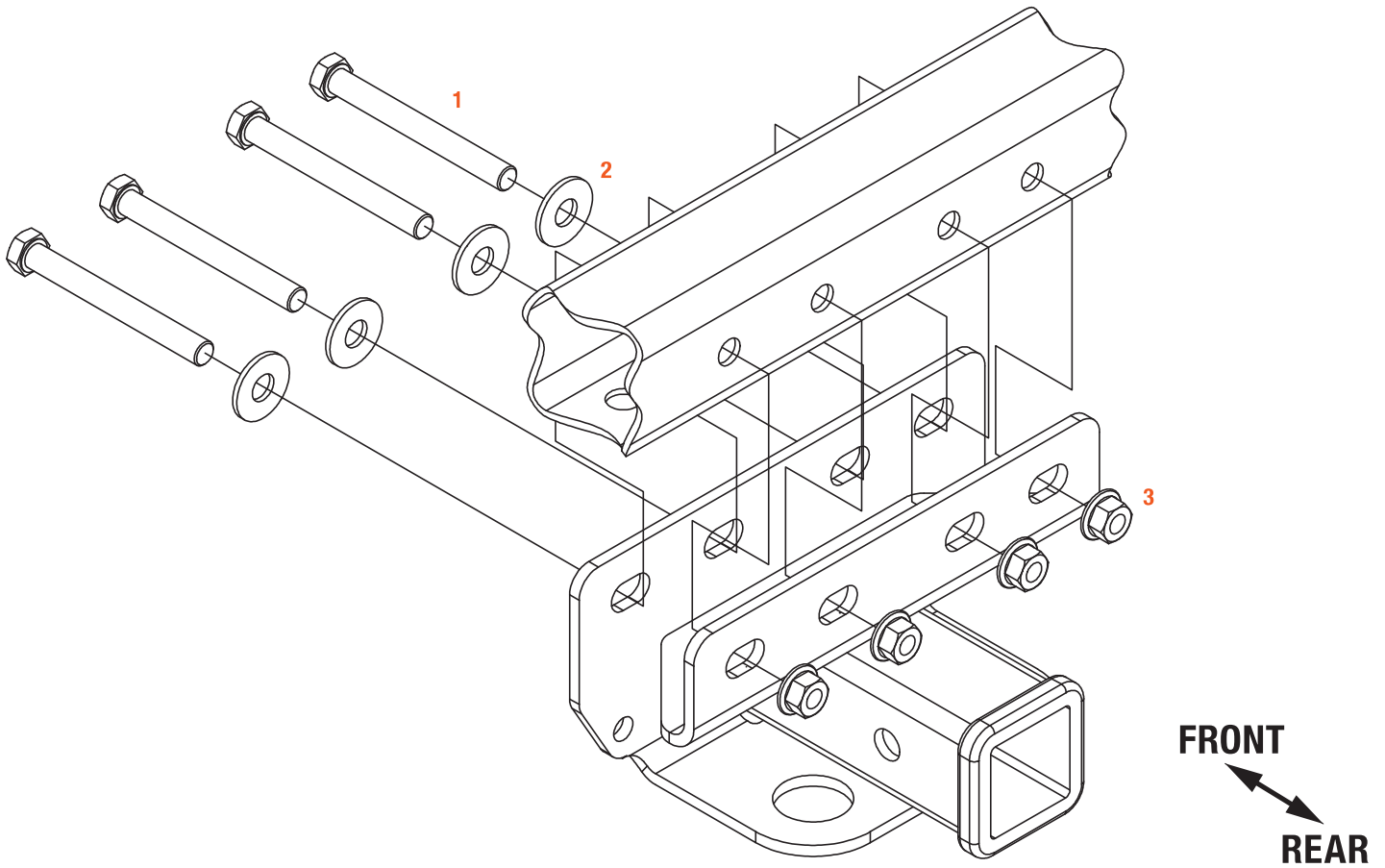

Note

If the vehicle does not have a metal bracket on the bottom of the bumper beam, skip to step 5.



Step 1

Disconnect the electrical connector behind the bumper near the wheel well on each side of the vehicle.



Step 2

Remove two (2) bolts from the bottom of each frame rail using an 18mm socket. Remove the bolt from the back of the bumper closest to the frame on each side using a 13mm socket.



Step 3

Carefully open the rear gate and remove the rear bumper. Set it aside for reinstallation.



Step 4

Remove the electrical bracket by removing two (2) bolts using an 18mm socket. Remove the electrical cap from the bracket and return the bracket to the vehicle owner.



Step 5

Raise the hitch into position around the bumper beam and insert four 1/2" hex bolts (#1) and four conical-toothed washers (#2) through the hitch and holes in the bumper beam. Loosely secure the bolts with 1/2" serrated-flange nuts (#3).

Torque 1/2" hardware to 110 ft-lbs.



Step 6

If the bumper was removed, reinstall the bumper following steps 1-4 in reverse order. The electrical cap will mount into the slot on the hitch.



Final Installed Image



TOWING BASICS & SAFETY INFORMATION

For information on safely towing your trailer, visit curtmfg.com/understanding-towing.